

# 1N4148 MINIATURE ULTRA FAST SWITCHING DIODE

## FEATURES

- Hermetically sealed glass package
- Low cost
- Super fast recovery time
- Low leakage
- Low forward voltage drop
- High current capability

## MECHANICAL SPECIFICATION

ACTUAL SIZE OF  
DO-35 PACKAGE

1N4148

DO-35

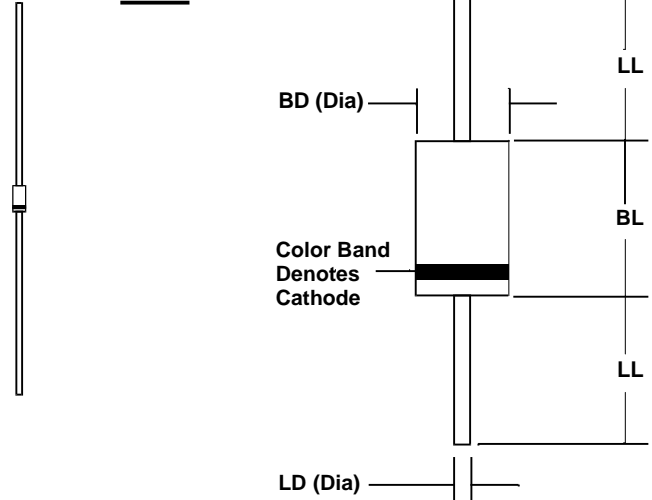

## MECHANICAL DATA

- Case: JEDEC DO-35 molded glass (U/L Flammability Rating 94V-0)
- Terminals: Plated axial leads
- Soldering: Per MIL-STD 202 Method 208 guaranteed
- Polarity: Color band denotes cathode
- Mounting Position: Any
- Weight: 0.005 Ounces (0.14 Grams)

Sym	Minimum		Maximum	
	In	mm	In	mm
BL	0.142	3.6	0.150	3.81
BD	0.07	1.78	0.072	1.83
LL	1.00	25.4		
LD	0.02	0.52	0.03	0.8

## MAXIMUM RATINGS & ELECTRICAL CHARACTERISTICS

Ratings at 25 °C ambient temperature unless otherwise specified.  
 Single phase, half wave, 60Hz, resistive or inductive load.  
 For capacitive loads, derate current by 20%.

PARAMETER (TEST CONDITIONS)	SYMBOL	RATINGS	UNITS
Series Number		1N4148	
Breakdown Voltage at $I_R = 5 \mu A$	$V_B$	75	VOLTS
Breakdown Voltage at $I_R = 100 \mu A$	$V_B$	100	
Maximum Peak Recurrent Reverse Voltage	$V_{RRM}$	75	
Average Forward Rectified Current @ $T_A = 50^\circ C$ , Lead length = 0.375 in. (9.5 mm)	$I_o$	150	mA
Peak Forward Surge Current	$I_{FSM}$	1 4	AMPS
Maximum Forward Voltage at 10 mA DC	$V_{FM}$	1	VOLTS
Maximum Power Dissipation	$P_{FM}$	500	mW
Maximum Average DC Reverse Current	$I_{RM}$	25 5	nA $\mu A$
Maximum Reverse Recovery Time (Note 1)	$T_{RR}$	4	nS
Typical Junction Capacitance (Note 2)	$C_J$	4	pF
Operating and Storage Temperature Range	$T_J, T_{STG}$	-65 to +175	$^\circ C$

NOTES: (1) Measured at  $I_R = 10 \text{ mA}$ ,  $V_R = 6V$ ,  $R_L = 100\Omega$ ; recover to 1 mA  
 (2) Measured at 1MHz & applied reverse voltage of 0 volts DC

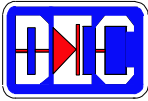

# 1N4148 MINIATURE ULTRA FAST SWITCHING DIODE

## RATING & CHARACTERISTIC CURVES FOR THE 1N4148

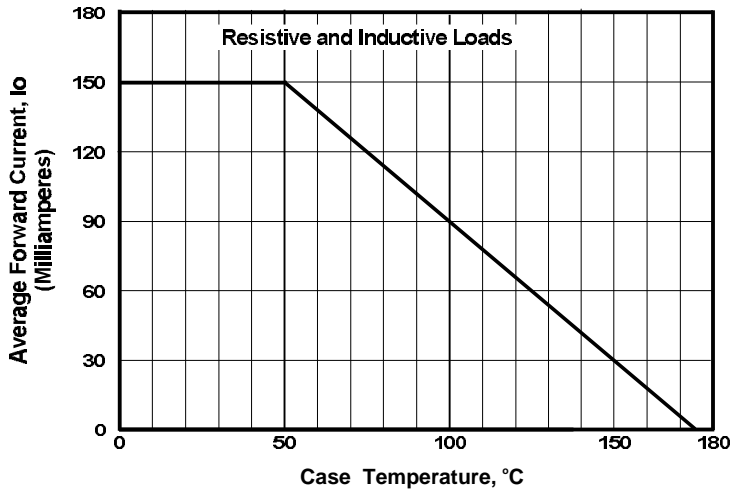

FIGURE 1. FORWARD CURRENT DERATING CURVE

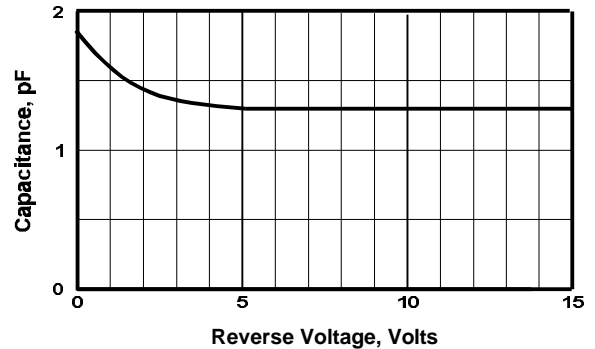

FIGURE 2. TYPICAL JUNCTION CAPACITANCE

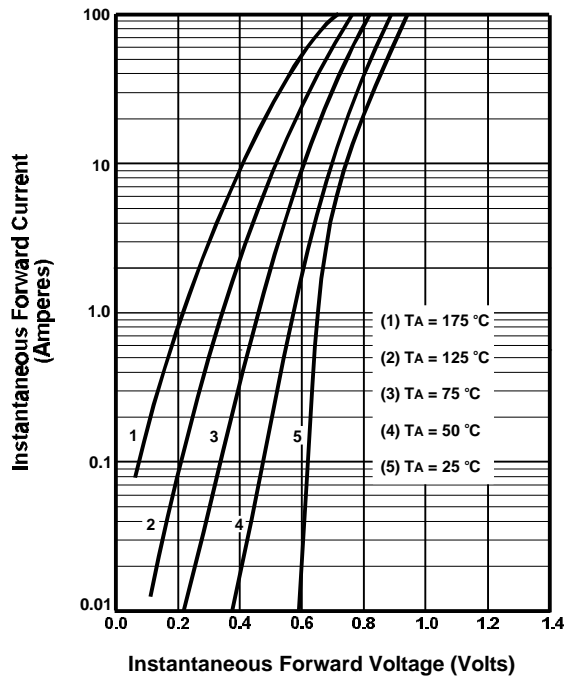

FIGURE 3. TYPICAL FORWARD CHARACTERISTIC PER DIODE

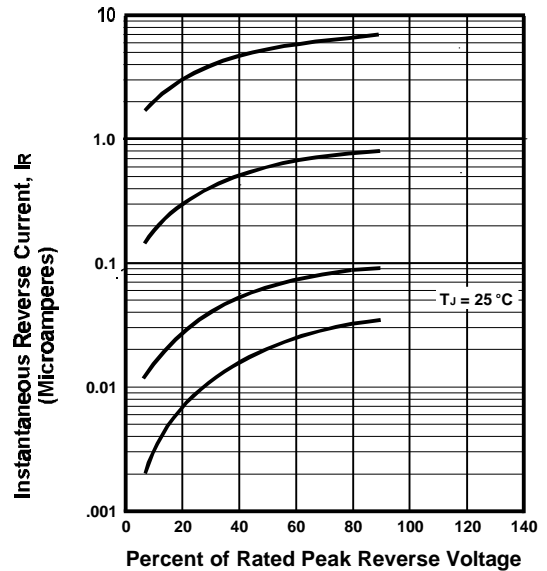

FIGURE 4. TYPICAL REVERSE CHARACTERISTICS